

# 0-10V Touch Glass Panel Dimmer

## Model No.: T18

1 zone / Touch glass panel / Brightness slide / Wireless remote control

### Features

- Touch panel 0-10V dimmer, output 1 channel 0-10V signal.
- Output connect with 0/1-10V dimmable driver.
- Ultra sensitive high strength glass touch panel with touch slide in the middle.
- Compatibility with RF 2.4G dimming remote control.
- Touch keys with LED indicator.
- White & Black glass panel available.



CE RoHS

### Technical Parameters

Input and Output		Safety and EMC		Environment	
Input voltage	AC100-240V	EMC standard (EMC)	ETSI EN 301 489-1 V2.2.3	Operation temperature	Ta: -30 °C ~ +55 °C
Output signal	0-10V (50mA)		ETSI EN 301 489-17 V3.2.4	Case temperature (Max.)	Ta: +65 °C
Dimming data		Safety standard	EN 62368-1:2020+A11:2020	IP rating	IP20
Input signal	Touch key + RF 2.4GHz	Radio Equipment(RED)	ETSI EN 300 328 V2.2.2	Package	
RF Control distance	10m(Barrier-free space)	Certification	CE,EMC,RED	Size	L112x W112 x H50mm
Dimming gray level	256 levels	Warranty		Gross weight	0.238kg
Dimming range	0-100%	Warranty	5 years		

### Mechanical Structures and Installations

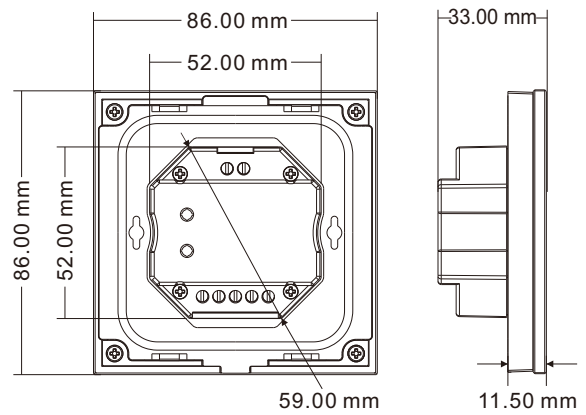
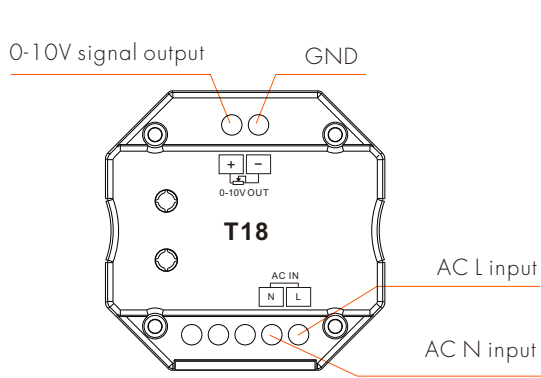

### Installation diagram:

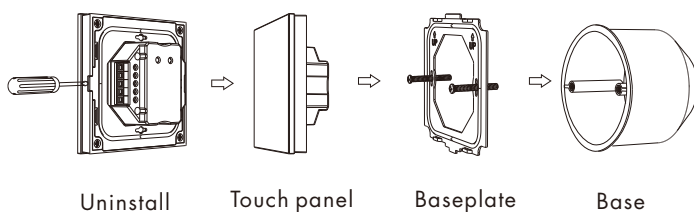

### Typical base as below:

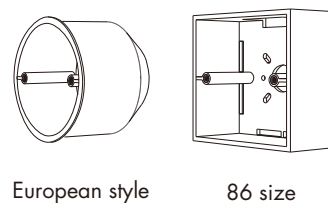



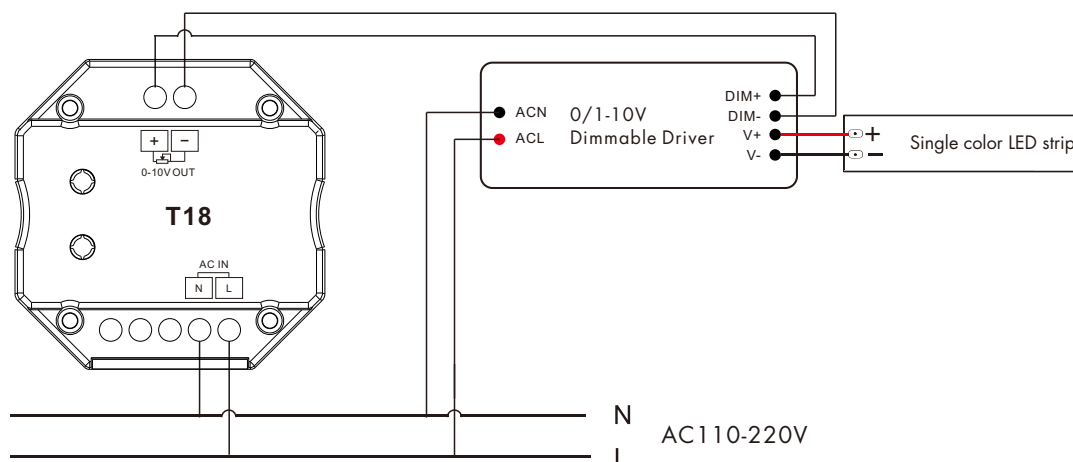

## Wiring diagram

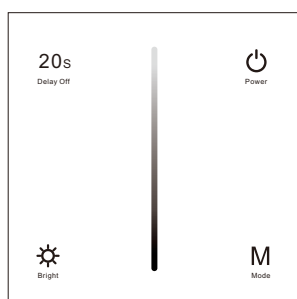

**Note:** We recommend the number of LED drivers connected to 0/1-10V dimmer does not exceed 100 pieces, the maximum length of the wires from dimmer to LED driver should be no more than 50 meters.

## Key function



-  — Turn on/off light.
-  — Play dynamic mode, 6 level speed.
-  — Turn off light after 20s.
-  — Brightness, 10 levels.

### Note:

The default output is 0-10V, if you want to 1-10V output, please touch power key to turn off light, then long press power key for 15s immediately, the output will become 1-10V. Touch power key to turn off light, then long press power key for 10s immediately, the output will return 0-10V.

## Match Remote Control (two match ways)

The 0-10V touch panel dimmer can also match with the RF dimming remote (optional). End user can choose the suitable match/delete ways. Two options are offered for selection:

### Use On/Off key

#### Match:

Turn on light, turn off, immediately press the On/Off key of the panel for 5s, then press on/off key (single zone remote) or zone key (multiple zone remote) of the RF remote within 5s.

The LED indicator fast flash 3 times means match is successful.

#### Delete:

Turn on light, turn off, immediately press the On/Off key of the panel for 10s to delete all match,

The LED indicator fast flash 6 times means all matched remotes were deleted.

### Use Power Restart

#### Match:

Switch off the power, then switch on power, repeat again, Immediately short press on/off key (single zone remote) or zone key (multiple zone remote) 3 times on the remote. The LED indicator blinks 3 times means match is successful.

#### Delete:

Switch off the power, then switch on power, repeat again, Immediately short press on/off key (single zone remote) or zone key (multiple zone remote) 5 times on the remote. The LED indicator blinks 5 times means all matched remotes were deleted.